

AVERY DENNISON MARKETING SPECIFICATION

HISTORY

THE SUBJECT MATTER DISCLOSED HEREIN EMBODIES PROPRIETARY INFORMATION WHICH IS THE CONFIDENTIAL PROPERTY OF THE AVERY DENNISON CO. NONE OF WHICH SHALL BE COPIED, REPRODUCED, DISCLOSED TO OTHERS, PUBLISHED OR USED IN WHOLE OR IN PART, FOR ANY PURPOSE OTHER THAN THAT FOR WHICH IT IS BEING MADE AVAILABLE WITHOUT THE EXPRESS ADVANCE WRITTEN PERMISSION OF A DULY AUTHORIZED AGENT OF THE COMPANY. THIS DOCUMENT IS THE PROPERTY OF THE AVERY DENNISON CO. AND IS TO BE RETURNED TO THE COMPANY ON DEMAND.

| REV. | DATE | DESCRIPTION |
|------|----------|---|
| A | 4/24/08 | RELEASE TO PRODUCTION |
| B | 08.15.18 | UPDATES TO NEW FORMAT; ADDED -0 TO PART NUMBER; ADDED SPECIAL CHARACTERISTIC NOTE; CHG ALL DIMS TO mm/in |

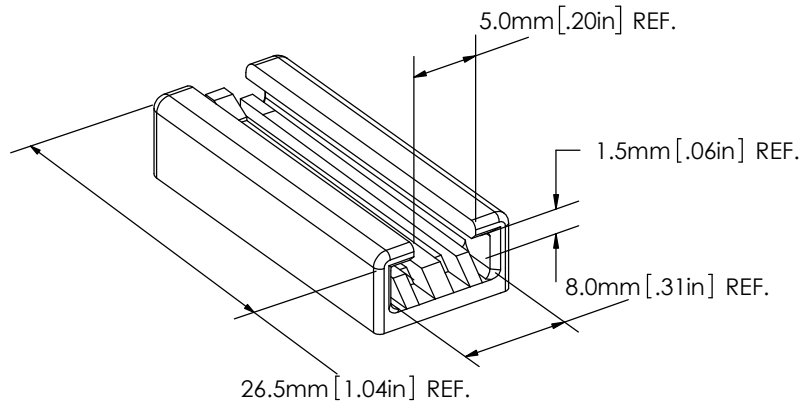
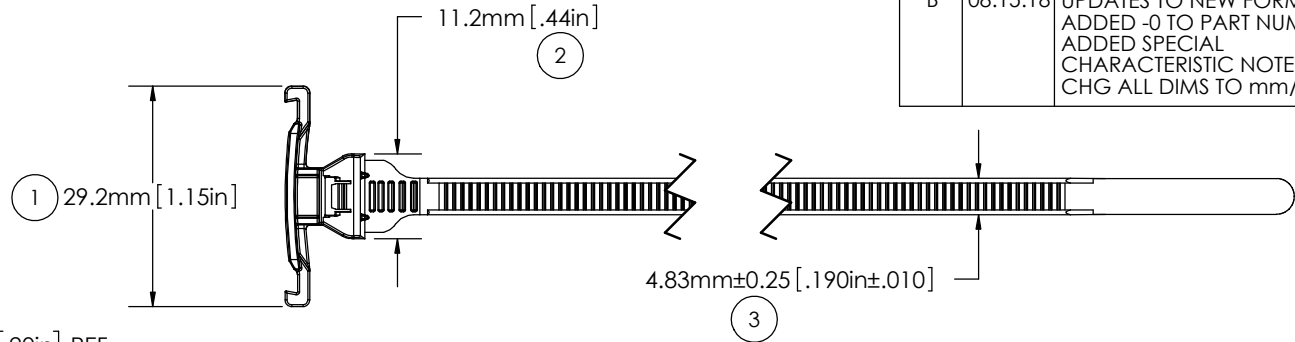

DETAIL A: MOUNTING SLOT

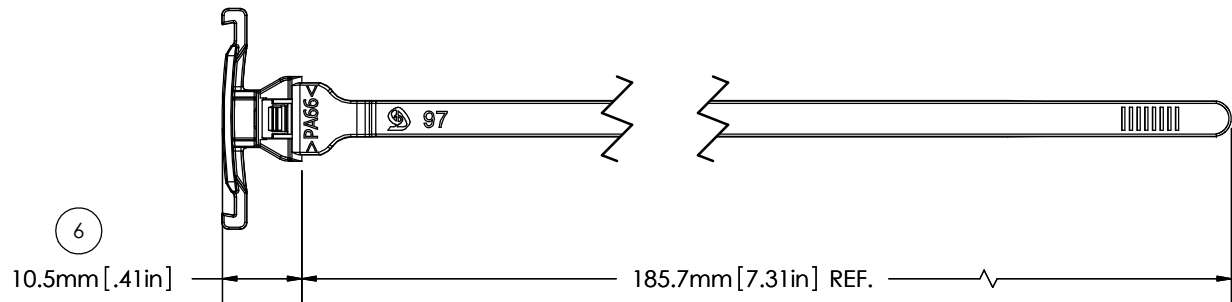
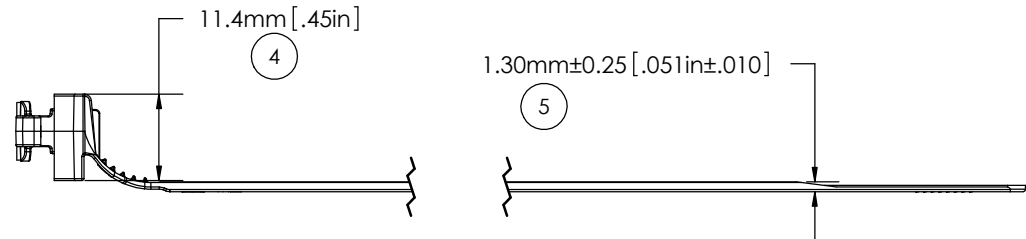

NOTES:
1. Δ = INDICATES SPECIAL CHARACTERISTIC

APPROVALS: ENG. APPR. *Daniel Gilbertson* 08.15.18
Q.A. APPR. *Rick Estano* 08.15.18



FASTENER DIVISION
FITCHBURG, MA 01420 U.S.A.
TEL. 1-800-225-5913
FAX. 978-353-8157

| | | |
|---|-------------------------------|--|
| 7 | Δ FLAMMABILITY RATING: | HB RATED PER FMVSS302 |
| 8 | Δ TENSILE STRENGTH: | 155N / 35 LBF MIN. |
| | MOUNTING: | SEE DETAIL A |
| | OPERATING TEMP RANGE: | -40°F (-40°C) TO 220°F (105°C) |
| | WEIGHT: | 1.8g |
| | BUNDLE DIAMETER: | ϕ 1.6mm [.06in] TO ϕ 44.5mm [1.75in] |
| | INSTALLATION TOOL: | 12001 - HAND TOOL 12500 - PNEUMATIC TOOL |
| | TOOL TENSION SETTING: | 6 - 8 |
| | PACKAGING: | 500/BAG, 10 BAGS/MASTER |

GENERAL TOLERANCE
UNLESS SPECIFIED \pm 0.5mm [.20in]

MATERIAL **NYLON 6/6,
IMPACT MODIFIED, HEAT STAB.**

DESCRIPTION
ADAPEX CONNECTOR TIE

.X \pm — .XXX \pm —
.XX \pm — ANGULAR: \pm 3°

COLOR
BLACK

PART NO. **20111-0** REV. **B**